

CASE HISTORY

Biscuits

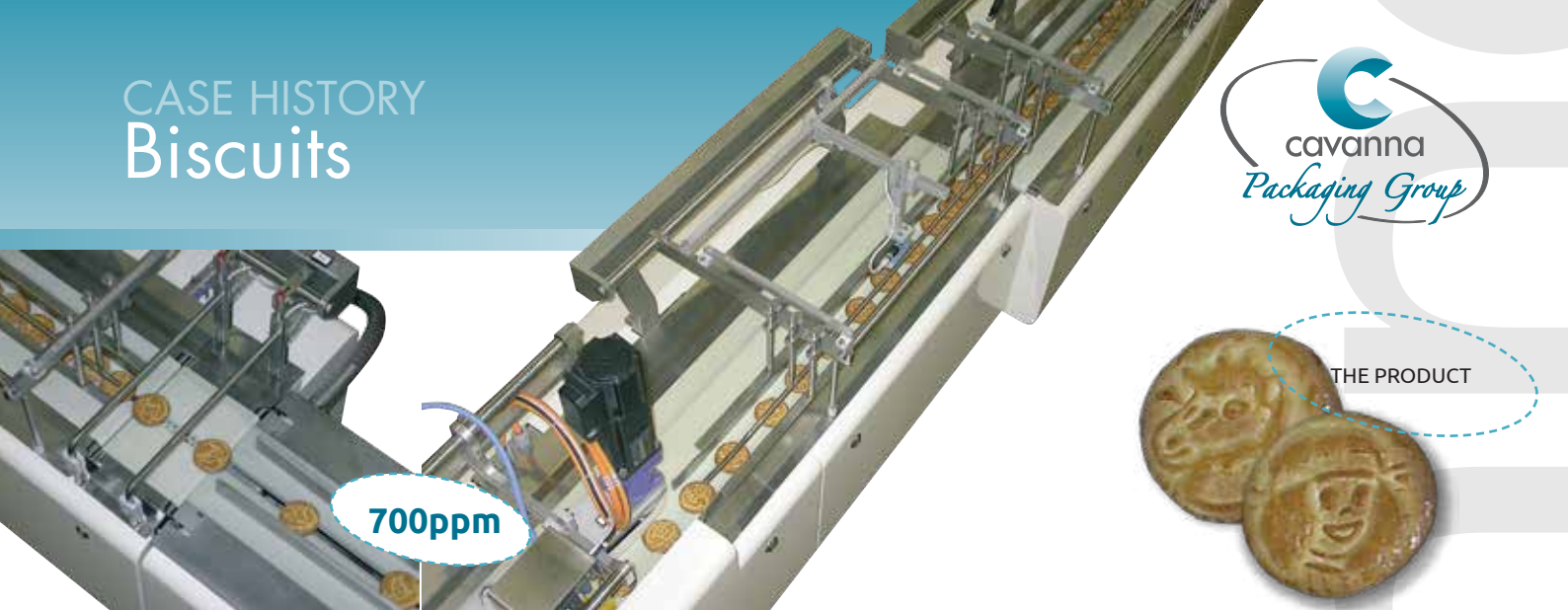

challenges

Customer packaging requirement was to get stacks of 3/4 biscuits each, depending on the size of the product. Biscuits were arriving flat to the wrapping line at a speed of 700 ppm and had to be stacked before being wrapped. The solution needed by the customer was therefore a high speed integrated wrapping system able to handle different product sizes with a high rate of flexibility.

How can you stack biscuits arriving flat at a high speed?

solutions / strengths

Cavanna presented an electronic programmable stacking system. This innovative device provides three main clear benefits:

- ✓ *the number of products per stack is programmable electronically*
- ✓ *it is definitely user friendly (extremely easy to set)*
- ✓ *lower possibilities of failures during the stacking process*

The line can wrap products of several sizes with very quick changeovers. It is also to point out that the product is handled individually and stacked before being wrapped. This enables a better product handling which guarantees lower microshocks.

results / benefits

The Cavanna solution granted an efficiency higher than 99%. With great flexibility in quick changeovers, the system was successfully integrated in the line achieving best performances also at high speeds.

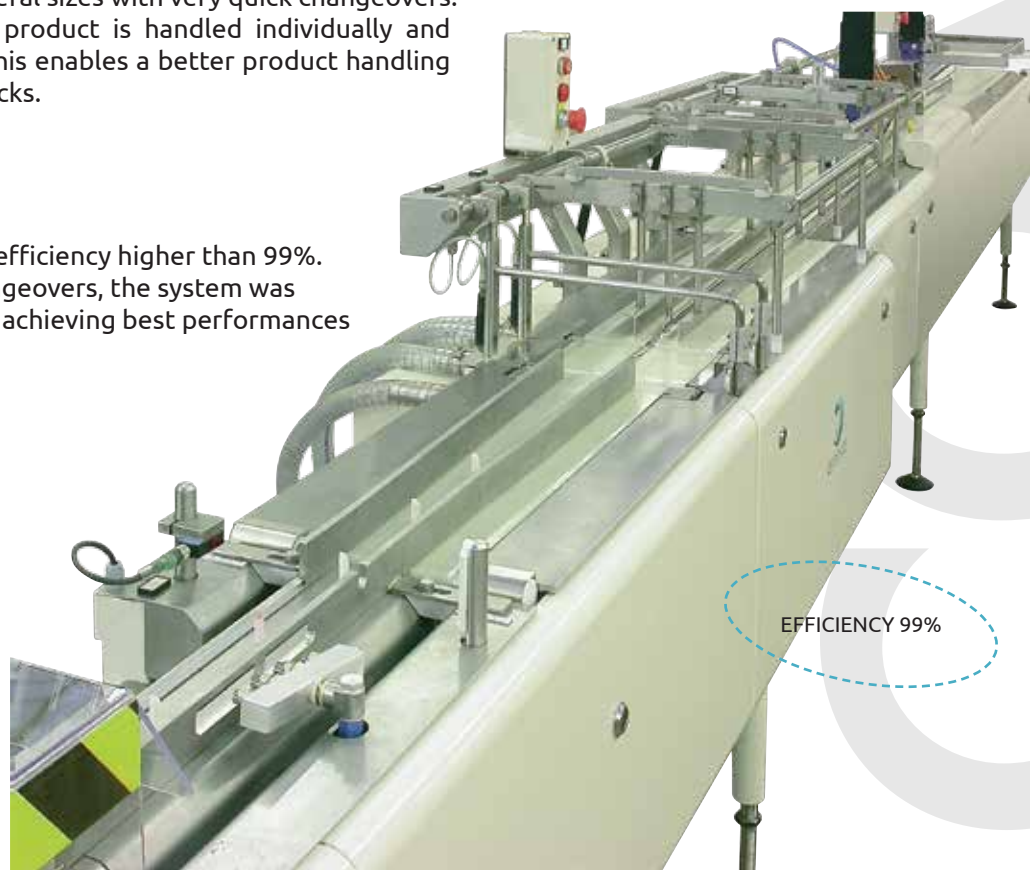
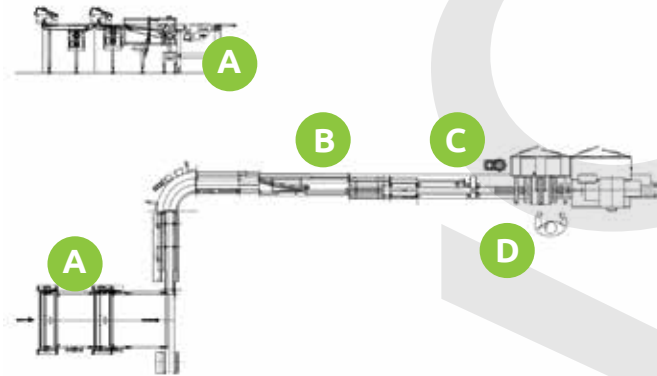

- A ROW DISTRIBUTING SYSTEM
- B IN-LINE LOADING SYSTEM
- C STACKING DEVICE
- D ZERO5 WRAPPER